

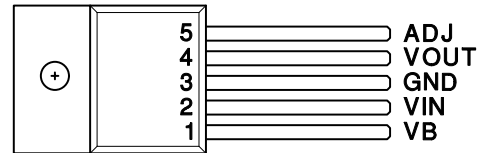

- Fast Transient Response
- 10-mA to 3-A Load Current
- Short Circuit Protection
- Maximum Dropout of 450-mV at 3-A Load Current
- Separate Bias and VIN Pins
- Available in Adjustable or Fixed-Output Voltages
- 5-Pin Package Allows Kelvin Sensing of Load Voltage
- Reverse Current Protection

5-PIN TO-220
T PACKAGE (TOP VIEW)



5-PIN TO-263
TD PACKAGE
(TOP VIEW)

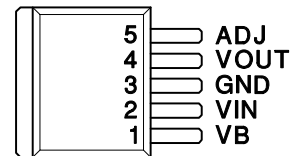

Note: Tab = Ground

description

The UC382 is a low-dropout-linear regulator providing a quick response to fast load changes. Combined with its precision on-board reference, the UC382 excels at driving GTL and BTL buses. Due to its fast response to load transients, the total capacitance required to decouple the regulator's output can be significantly decreased when compared to standard LDO linear regulators.

Dropout voltage (VIN to VOUT) is only 450 mV maximum at 100°C and 350 mV typical at 3-A load.

The onboard bandgap reference is stable with temperature and scaled for a 1.2-V input to the internal-power amplifier. The UC382 is available in fixed-output voltages of 1.5 V, 2.1 V, or 2.5 V. The output voltage of the adjustable version can be set with two external resistors. If the external resistors are omitted, the output voltage defaults to 1.2 V.

block diagram

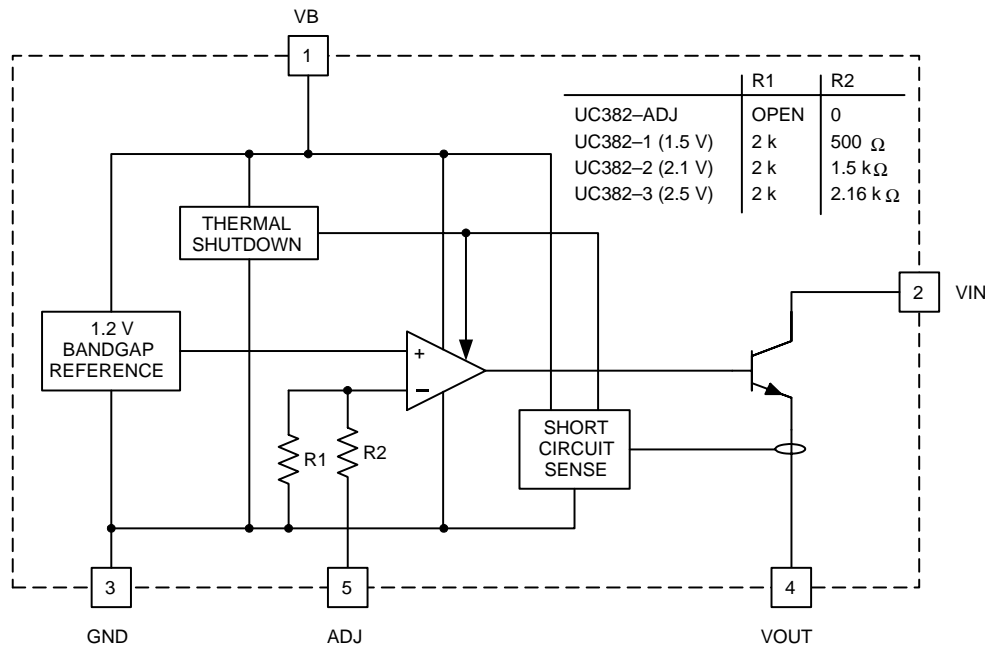

UDG-00080



Please be aware that an important notice concerning availability, standard warranty, and use in critical applications of Texas Instruments semiconductor products and disclaimers thereto appears at the end of this data sheet.

UC282-1, UC282-2, UC282-3, UC282-ADJ, UC382-1, UC382-2, UC382-3, UC382-ADJ FAST LDO LINEAR REGULATOR

SLUS317A – JANUARY 2000 - REVISED MAY 2001

absolute maximum ratings over operating free-air temperature (unless otherwise noted)†

VB	13 V
VIN	7.5 V
Output voltage	1.2 V to 6.0 V
Storage temperature, T _{stg}	-65°C to 150°C
Junction temperature, T _J	-55°C to 150°C
Lead temperature (soldering, 10 seconds)	300°C

† Stresses beyond those listed under “absolute maximum ratings” may cause permanent damage to the device. These are stress ratings only, and functional operation of the device at these or any other conditions beyond those indicated under “recommended operating conditions” is not implied. Exposure to absolute-maximum-rated conditions for extended periods may affect device reliability.

‡ Currents are positive into, negative out of the specified terminal. Consult Packaging Section of Databook for thermal limitations and considerations of packages.

AVAILABLE OPTIONS

T _J	PACKAGED DEVICES							
	TO-220 (T)				TO-263 (TD)			
	OUTPUT VOLTAGE				OUTPUT VOLTAGE			
	1.5 V	2.1 V	2.5 V	1.2 V or ADJ	1.5 V	2.1 V	2.5 V	1.2 V or ADJ
-40°C to 100°C	282T-1	282T-2	282T-3	282T-ADJ	282TD-1	282TD-2	282TD-3	282TD-ADJ
0°C to 100°C	382T-1	382T-2	382T-3	382T-ADJ	382TD-1	382TD-2	382TD-3	382TD-ADJ

electrical characteristics, T_A = -40°C to 100°C for the UC282-X series and 0°C to 100°C for the UC382-X, V_B = 5 V, V_{IN} = 3.3 V, V_{OUT} = 2.5 V for the UC382-ADJ, T_A = T_J, (unless otherwise stated)

UC382-3 fixed 2.5 V, 3-A family

PARAMETERS	TEST CONDITIONS	MIN	TYP	MAX	UNITS
Output voltage (I _{VOUT} = 100 mA)	UC382-3	2.475	2.500	2.525	V
	UC282-3	2.450	2.500	2.525	V
Load regulation	I _{VOUT} = 10 mA to 3 A		0.5	4	mV
VIN PSSR		80	100		dB
VB PSSR		50	60		dB
VIN dropout voltage = VIN-VOUT	I _{VOUT} = 3 A, T _J = 25°C		350	425	mV
	I _{VOUT} = 3 A, UC382-3		350	450	mV
	I _{VOUT} = 3 A, UC282-3		350	500	mV
VB dropout = VB-VOUT	I _{VOUT} = 3 A, UC382-3		1.8	2.10	V
	I _{VOUT} = 3 A, UC282-3		1.8	2.20	V
Short circuit current limit		3.3		4.5	A
VB current	I _{VOUT} = 10 mA		6	11	mA
	I _{VOUT} = 3 A		18	60	mA
VIN current	I _{VOUT} = 3 A	2.94	2.97		A



POST OFFICE BOX 655303 • DALLAS, TEXAS 75265

UC282-1, UC282-2, UC282-3, UC282-ADJ, UC382-1, UC382-2, UC382-3, UC382-ADJ FAST LDO LINEAR REGULATOR

SLUS317A – JANUARY 2000 - REVISED MAY 2001

electrical characteristics, $T_A = -40^{\circ}\text{C}$ to 100°C for the UC282-X series and 0°C to 100°C for the UC382-X, $V_B = 5\text{ V}$, $V_{IN} = 3.3\text{ V}$, $V_{OUT} = 2.5\text{ V}$ for the UC382-ADJ, $T_A = T_J$, (unless otherwise stated)

UC382-2 fixed 2.1 V, 3-A family

PARAMETERS	TEST CONDITIONS	MIN	TYP	MAX	UNITS
Output voltage ($I_{VOUT} = 100\text{ mA}$)	UC382-2	2.079	2.100	2.121	V
	UC282-2	2.058	2.100	2.121	V
Load regulation	$I_{VOUT} = 10\text{ mA}$ to 3 A		0.5	4	mV
VIN PSSR		80	100		dB
VB PSSR		52	62		dB
VIN dropout voltage = $V_{IN} - V_{OUT}$	$I_{VOUT} = 3\text{ A}$, $T_J = 25^{\circ}\text{C}$		350	425	mV
	$I_{VOUT} = 3\text{ A}$, UC382-2		350	450	mV
	$I_{VOUT} = 3\text{ A}$, UC282-2		350	500	mV
VB dropout = $V_B - V_{OUT}$	$I_{VOUT} = 3\text{ A}$, UC382-2		1.8	2.10	V
	$I_{VOUT} = 3\text{ A}$, UC282-2		1.8	2.20	V
Short circuit current limit		3.3		4.5	A
VB current	$I_{VOUT} = 10\text{ mA}$		6	11	mA
	$I_{VOUT} = 3\text{ A}$		18	60	mA
VIN current	$I_{VOUT} = 3\text{ A}$	2.94	2.97		A

UC382-1 fixed 1.5 V, 3-A family

PARAMETERS	TEST CONDITIONS	MIN	TYP	MAX	UNITS
Output voltage ($I_{VOUT} = 100\text{ mA}$)	UC382-1	1.485	1.500	1.515	V
	UC282-1	1.470	1.500	1.515	V
Load regulation	$I_{VOUT} = 10\text{ mA}$ to 3 A		0.5	4	mV
VIN PSSR		80	100		dB
VB PSSR		55	65		dB
VIN dropout voltage = $V_{IN} - V_{OUT}$	$I_{VOUT} = 3\text{ A}$, $T_J = 25^{\circ}\text{C}$		350	425	mV
	$I_{VOUT} = 3\text{ A}$, UC382-1		350	450	mV
	$I_{VOUT} = 3\text{ A}$, UC282-1		350	500	mV
VB dropout = $V_B - V_{OUT}$	$I_{VOUT} = 3\text{ A}$, UC382-1		1.8	2.10	V
	$I_{VOUT} = 3\text{ A}$, UC282-1		1.8	2.20	V
Short circuit current limit		3.3		4.5	A
VB current	$I_{VOUT} = 10\text{ mA}$		6	11	mA
	$I_{VOUT} = 3\text{ A}$		18	60	mA
VIN current	$I_{VOUT} = 3\text{ A}$	2.94	2.97		A



UC282-1, UC282-2, UC282-3, UC282-ADJ, UC382-1, UC382-2, UC382-3, UC382-ADJ FAST LDO LINEAR REGULATOR

SLUS317A – JANUARY 2000 - REVISED MAY 2001

electrical characteristics, $T_A = -40^{\circ}\text{C}$ to 100°C for the UC282-X series and 0°C to 100°C for the UC382-X, $V_B = 5\text{ V}$, $V_{IN} = 3.3\text{ V}$, $V_{OUT} = 2.5\text{ V}$ for the UC382-ADJ, $T_A = T_J$, (unless otherwise stated)

UC382-ADJ adjustable, 3-A family

PARAMETERS	TEST CONDITIONS	MIN	TYP	MAX	UNITS
ADJ voltage ($I_{V_{OUT}} = 100\text{ mA}$)	UC382-ADJ	1.188	1.200	1.212	V
	UC282-ADJ	1.176	1.200	1.212	V
Load regulation	$I_{V_{OUT}} = 10\text{ mA}$ to 3 A		0.5	4	mV
VIN PSSR	VOUT programmed for 2.5 V	80	100		dB
VB PSSR	VOUT programmed for 2.5 V	50	60		dB
VIN dropout voltage = $V_{IN} - V_{OUT}$	$I_{V_{OUT}} = 3\text{ A}$, $T_J = 25^{\circ}\text{C}$		350	425	mV
	$I_{V_{OUT}} = 3\text{ A}$, UC382-ADJ		350	450	mV
	$I_{V_{OUT}} = 3\text{ A}$, UC282-ADJ		350	500	mV
VB dropout = $V_B - V_{OUT}$	$I_{V_{OUT}} = 3\text{ A}$, UC382-ADJ		1.8	2.10	V
	$I_{V_{OUT}} = 3\text{ A}$, UC282-ADJ		1.8	2.20	V
Short circuit current limit		3.3		4.5	A
VB current	$I_{V_{OUT}} = 10\text{ mA}$		6	11	mA
	$I_{V_{OUT}} = 3\text{ A}$		18	60	mA
VIN current	$I_{V_{OUT}} = 3\text{ A}$	2.94	2.97		A

pin descriptions

ADJ: In the adjustable version, the user programs the output voltage with two external resistors. The resistors should be 0.1% for high accuracy. The output amplifier is configured as a non-inverting-operational amplifier. The resistors should meet the criteria of $R_3 \parallel R_4 < 100\ \Omega$. Connect ADJ to VOUT for an output voltage of 1.2 V. Note that the point at which the feedback network is connected to the output is the Kelvin sense point. For -1, -2, and -3 versions, ADJ pin is tied to VOUT to obtain specified output voltage.

GND: For accurate results, the GND pin should be referenced to the load ground.

VB: Supplies power to all circuits of the regulator except the collector of the output-power transistor. The 2-V headroom from VB to VOUT allows the use of a Darlington output stage for inherently-low-output impedance and fast response. (Dropout is derated for junction temperatures below 0°C .)

VIN: Supplies the current to the collector of the output-power transistor only. The dropout ($V_{IN} - V_{OUT}$) is under 100 mV for light loads; maximum dropout is 450 mV at 3 A for $T_J = 0^{\circ}\text{C}$ to 100°C . (Dropout is derated for junction temperatures over 100°C .) At full load, the majority of the VB current is going to the load.

VOUT: This pin should be connected to the load via a low impedance path. Avoid connectors which add significant inductance and resistance. Note that even though a Kelvin sense is available through a 5-pin package, care must be taken since voltage drops along wire traces add to the dropout voltage.



pin descriptions (continued)

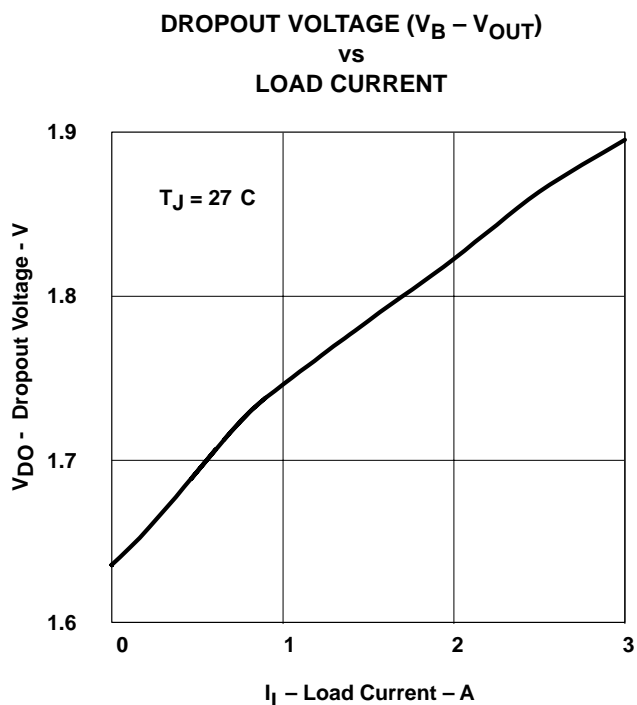

Figure 1

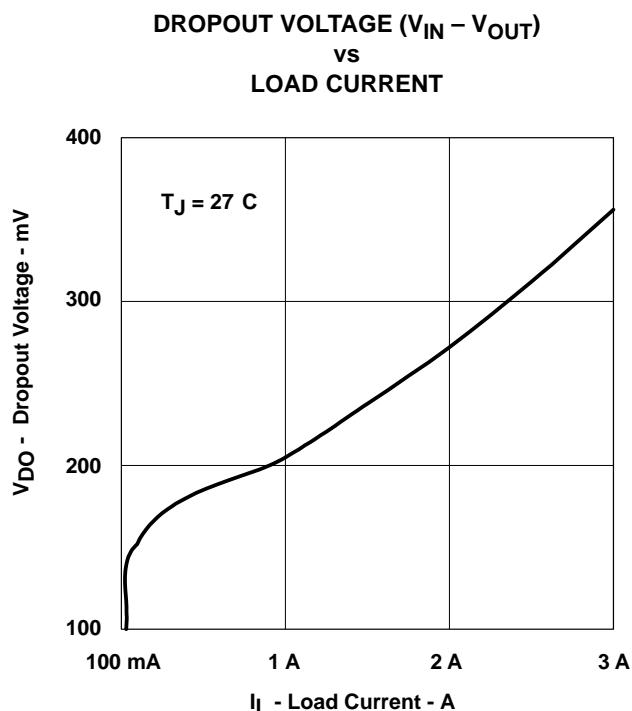

Figure 2

APPLICATION INFORMATION

The UC382 is easy to use. The adjustable version requires two 0.1% resistors to set the output voltage. The fixed versions of the UC382 require no external resistors. All versions of the UC382 require decoupling capacitors on the input and output. In a typical application, V_B and V_{IN} are driven from switching power supplies which may have large filter capacitors at their outputs. If the UC382 is further than 12 inches from the power supply, it is recommended to add local decoupling as close as possible to the linear regulator.

Decouple the output of the UC382 with at least 100 μ F of high-quality tantalum or Sanyo OSCON capacitors close to the V_{OUT} pin for maximum stability. Many applications involving Ultra-Fast GTL or BTL applications require additional capacitance close to the load. The exact amount will vary according to speed and magnitude of the load transients and the tolerance allowed for transients on V_{OUT} . When specifying the decoupling capacitors, the series resistance of the capacitor bank is an important factor in its ability to filter load transients.

The UC382 allows for Kelvin sensing the voltage at the load. This improves regulation performance and eliminates the voltage drops due to wire-trace resistance. This voltage drop must be added to the headroom (V_{IN} to V_{OUT} and V_B to V_{OUT}). The dropout of 450 mV is measured at the pins and does not include additional drops due to trace resistance. The minimum load current is 10 mA.

Two or more UC382's may be used in parallel. While stable, this arrangement does degrade the transient response.

UC282-1, UC282-2, UC282-3, UC282-ADJ, UC382-1, UC382-2, UC382-3, UC382-ADJ FAST LDO LINEAR REGULATOR

SLUS317A – JANUARY 2000 - REVISED MAY 2001

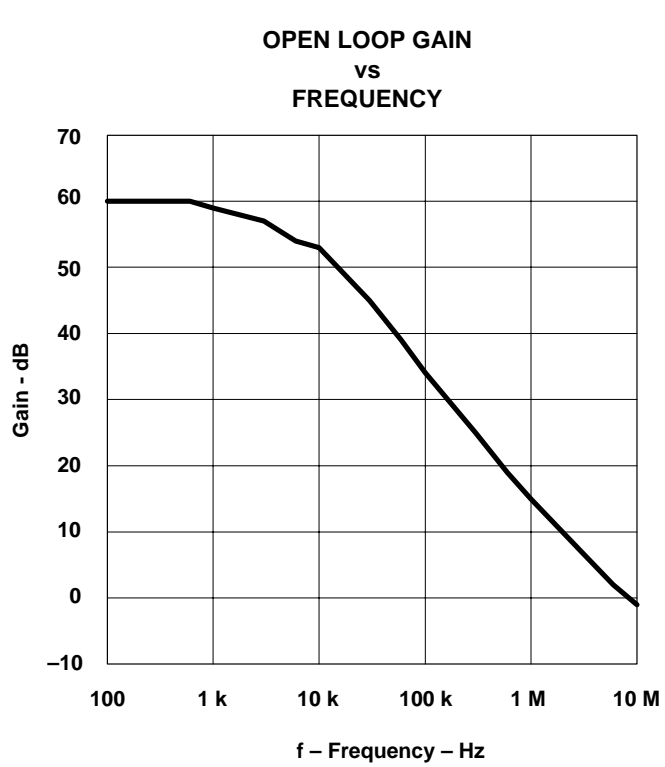

Figure 3

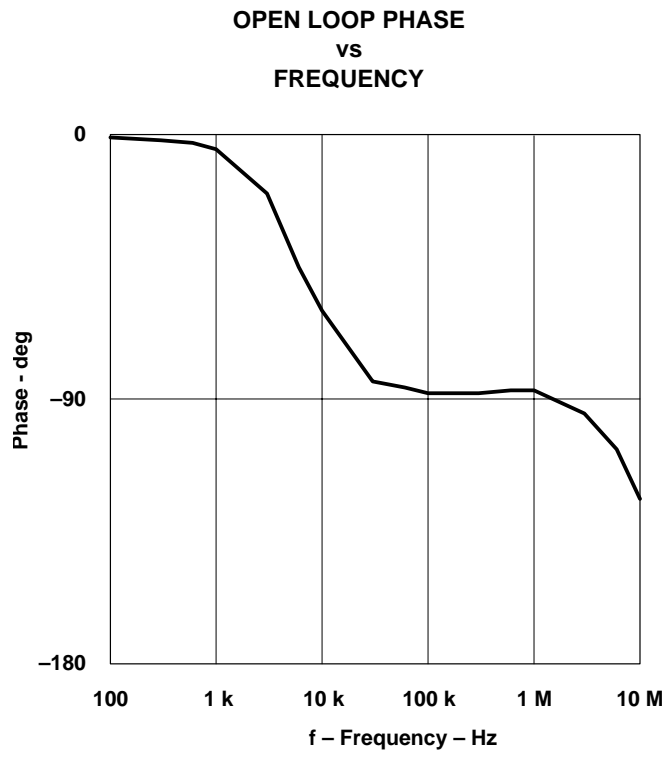

Figure 4

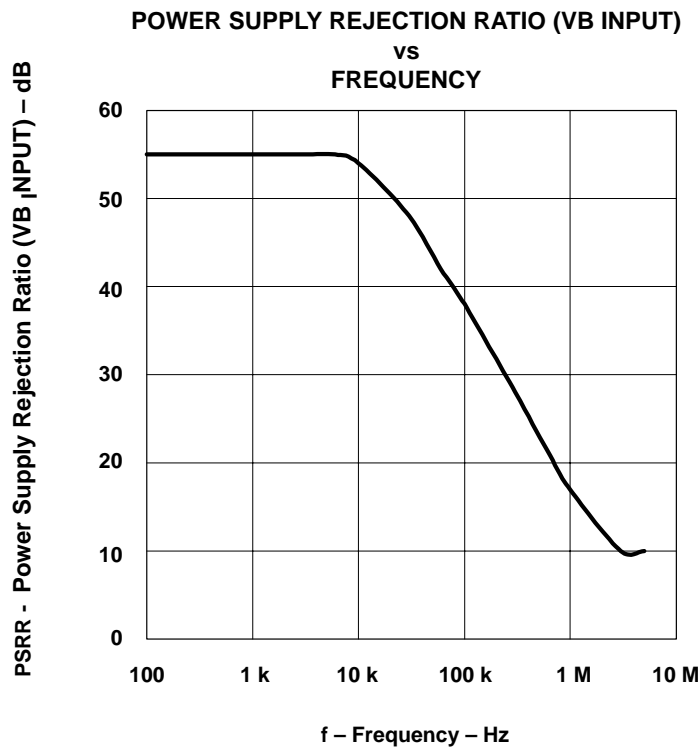
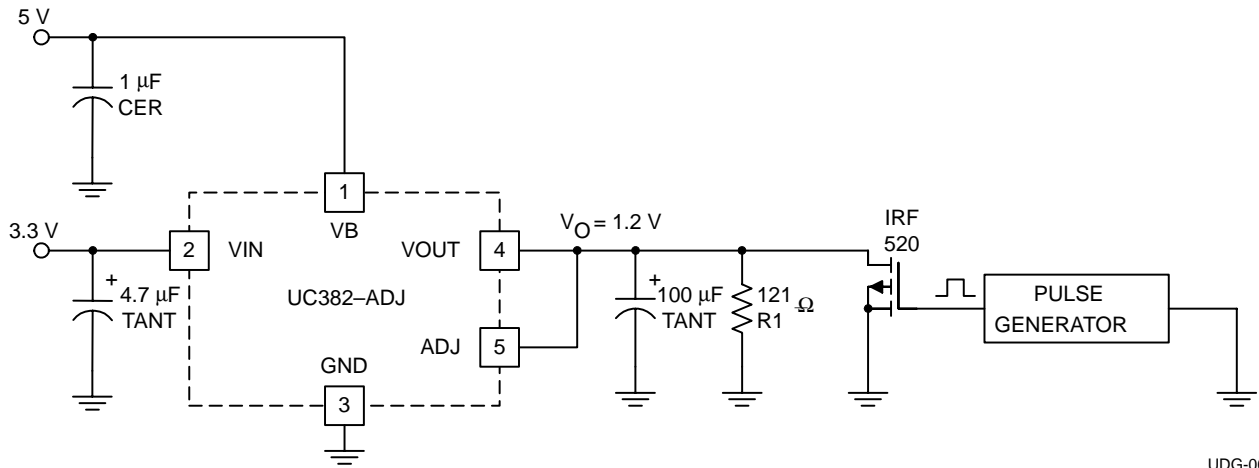

Figure 5



APPLICATION INFORMATION



UDG-00081

Figure 6. Transient Test Circuit

10 mA to 3 A/ s Load Transient Response

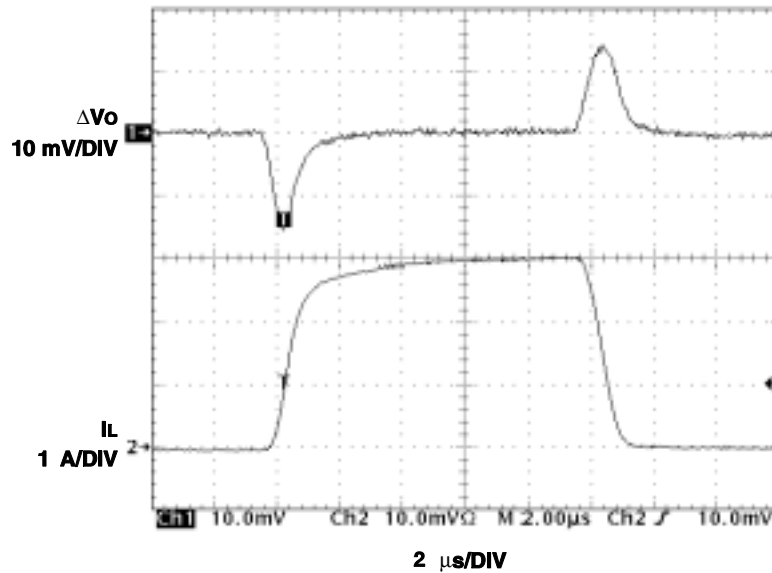
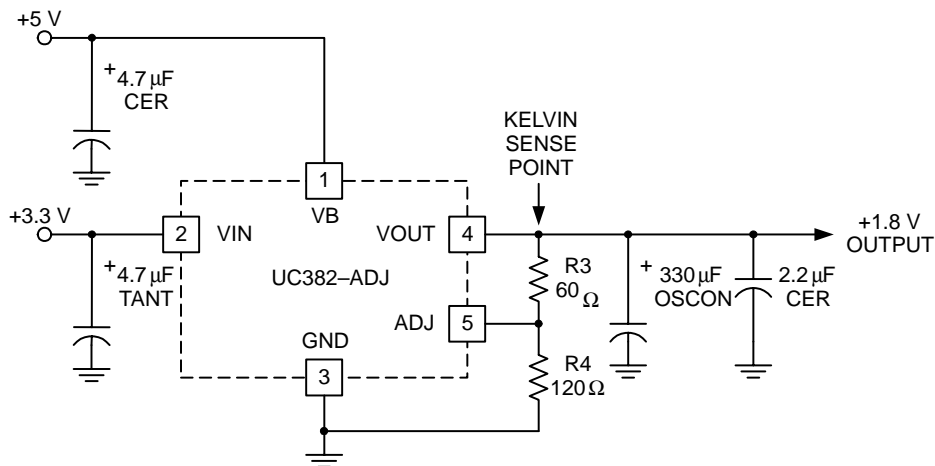

Figure 7

UC282-1, UC282-2, UC282-3, UC282-ADJ, UC382-1, UC382-2, UC382-3, UC382-ADJ FAST LDO LINEAR REGULATOR

SLUS317A – JANUARY 2000 - REVISED MAY 2001

APPLICATION INFORMATION



UDG-00082

Figure 8. Typical UC382-ADJ Application

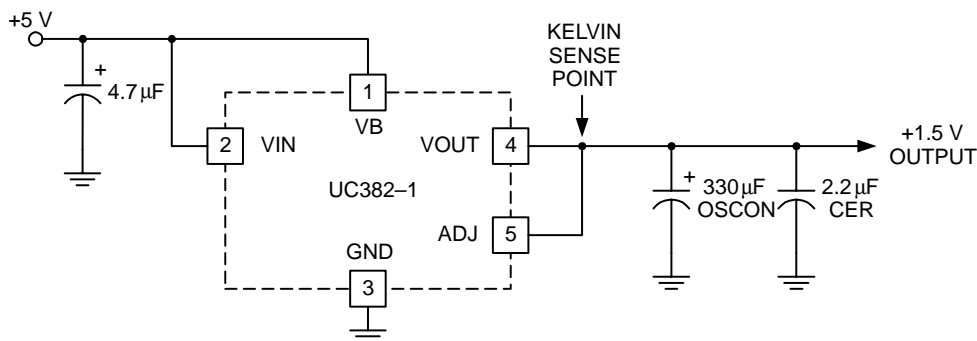

UDG-00083

Figure 9. Typical UC382-1, -2, or -3 Application

IMPORTANT NOTICE

Texas Instruments and its subsidiaries (TI) reserve the right to make changes to their products or to discontinue any product or service without notice, and advise customers to obtain the latest version of relevant information to verify, before placing orders, that information being relied on is current and complete. All products are sold subject to the terms and conditions of sale supplied at the time of order acknowledgment, including those pertaining to warranty, patent infringement, and limitation of liability.

TI warrants performance of its products to the specifications applicable at the time of sale in accordance with TI's standard warranty. Testing and other quality control techniques are utilized to the extent TI deems necessary to support this warranty. Specific testing of all parameters of each device is not necessarily performed, except those mandated by government requirements.

Customers are responsible for their applications using TI components.

In order to minimize risks associated with the customer's applications, adequate design and operating safeguards must be provided by the customer to minimize inherent or procedural hazards.

TI assumes no liability for applications assistance or customer product design. TI does not warrant or represent that any license, either express or implied, is granted under any patent right, copyright, mask work right, or other intellectual property right of TI covering or relating to any combination, machine, or process in which such products or services might be or are used. TI's publication of information regarding any third party's products or services does not constitute TI's approval, license, warranty or endorsement thereof.

Reproduction of information in TI data books or data sheets is permissible only if reproduction is without alteration and is accompanied by all associated warranties, conditions, limitations and notices. Representation or reproduction of this information with alteration voids all warranties provided for an associated TI product or service, is an unfair and deceptive business practice, and TI is not responsible nor liable for any such use.

Resale of TI's products or services with statements different from or beyond the parameters stated by TI for that product or service voids all express and any implied warranties for the associated TI product or service, is an unfair and deceptive business practice, and TI is not responsible nor liable for any such use.

Also see: [Standard Terms and Conditions of Sale for Semiconductor Products](http://www.ti.com/sc/docs/stdterms.htm). www.ti.com/sc/docs/stdterms.htm

Mailing Address:

Texas Instruments
Post Office Box 655303
Dallas, Texas 75265