

SIR Endec for IrDA Applications Integrated Interface Circuits



ULC Technology:

High-performance gate array package using multiple metal layer CMOS technology featuring sub-micron channel lengths (0.35 μm)

Description

The TOIM4232 Endec IC provides proper pulse shaping for the SIR IrDA[®] front end infrared transceivers as of the 4000-series. For transmitting the TOIM4232 shortens the RS232 output signal to IrDA compatible electrical pulses to drive the infrared transmitter. In the receive mode, the TOIM4232 stretches the received infrared pulses to the proper bit width depending on the operating bit rate. The IrDA bit rate varies from 2.4 kbit/s to 115.2 kbit/s.

The TOIM4232 is using a crystal clock 3.6864 MHz for its pulse stretching and shortening. The clock can be generated by the internal oscillator. An external clock can be used, too. The TOIM4232 is programmable to operate from 1200 bit/s to 115.2 kbit/s by the communication software through the RS232 port. The output pulses are software programmable as either 1.627 μs or 3/16 of bit time. The typical power consumption is very low with about 10 mW in operational state and in the order of a few microwatts in standby mode.

Features

- Pulse shaping function (shortening and stretching) used in SIR IrDA[®] applications
- Directly interfaces the SIR transceiver TFD... series to an RS232 port
- Programmable baud clock generator (1200 Hz to 115.2 kHz), 13 baud rates
- 3/16 bit pulse duration or 1.627 μs pulse selectable
- SO16 – package
- 3 V operation voltage, 5 V tolerant inputs
- Low operating current

Block Diagram

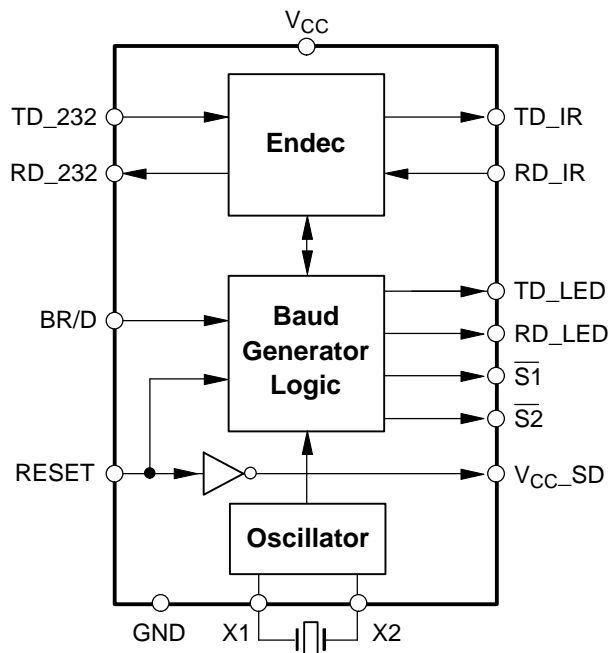

Figure 1. Block diagram

Pin Assignment and Description

Pin	Symbol	Function	I/O	Active
1	RESET	Resets all internal registers. Initially must be HIGH ("1") to reset internal registers. When HIGH, the TOIM4232 sets the IrDA default bit rate of 9600 bit/s, sets pulse width to 1.627 μ s. The V _{CC_SD} output is simply an inverted reset signal which allows to shut down of a TFDx4x00 transceiver when applying the reset signal to the TOIM4232. When using devices with external SD like TFDS4203, the reset line can be used directly as shut down signal. The internal oscillator is stopped during RESET active. RESET pin can be controlled by either the RTS or DTR line through RS232 level converter. Minimum hold time for reset: 1 μ s.	I	HIGH
2	BR/ D	Baud Rate control/ Data. BR/ D = 0, data communication mode: RS232 TXD data line is connected (via a level shifter) to TD_232 input pin. The TXD – signal is appropriately shortened and applied to the output TD_IR, driving the TXD input of the IR transceiver. The RXD line of the transceiver is connected to the RD_IR input. This signal is stretched to the correct bit length according the programmed bit rate and is routed to the RS232 RXD line at the RD_232 pin. BR/ D = 1, programming mode: Data received from the RS232 port is interpreted as Control Word. The Control Word programs the baud rate width will be effective as soon as BR/ D return to LOW.	I	
3	RD_232	Received signal data output of stretched signal to the RS232 RXD line (using level converter).	O	HIGH
4	TD_232	Input of the signal to be transmitted from the RS232 port TXD line (passing the level converter).	I	HIGH
5	V _{CC_SD}	Outputs an inverted RESET signal. Can be used to shut down the power supply of a 4000 series transceiver (e.g., TFDU4100). V _{CC} shut-down output function. This pin can be used to shut down a transceiver (e.g., TFDx4xxx). Output polarity: Inverted RESET input.	O	LOW
6	X1	Crystal input clock, 3.6864 MHz nominal. Input for external clock *)	I	
7	X2	Crystal *)	I	
8	GND	Ground in common with the RS232 port and IrDA transceiver ground		
9	TD_LED	Transmit LED indicator driver. Use 180 Ω current limiting resistor in series to LED to connect to V _{CC} . (V _{CC} = 3.3 V)	O	LOW
10	RD_LED	Receive LED indicator driver. Use 180 Ω current limiting resistor in series to LED to connect to V _{CC} . (V _{CC} = 3.3 V)	O	LOW
11	NC	No connection		
12	S1	User Programmable Bit. Can be used to turn ON/ OFF a front-end infrared transceiver (e.g., an infrared module at the adapter front)	O	LOW
13	S2	User Programmable Bit. Can be used to turn ON/ OFF a front-end infrared transceiver (e.g., an infrared module at the adapter back)	O	LOW
14	TD_IR	Data output of shortened signal to the infrared transceiver	O	HIGH
15	RD_IR	Data input from the infrared transceiver	I	LOW
16	V _{CC}	Supply voltage	I	

*) Crystal should be connected as shown in figure 2. In addition connect a 100 k Ω resistor from Pin 6 to Pin 7 and from Pin 6 and Pin 7 a 22 pF capacitor to ground, respectively. When an external clock is available connect it to Pin 6 leaving Pin 7 open.

Application circuit

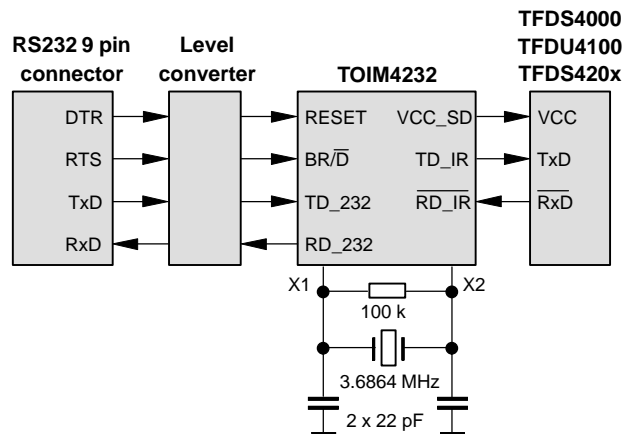

Figure 2. RS232 Port interface (external infrared adapter)

Table 1. Recommended Application Circuit Components

Component	Recommended Value	Vishay Part Number
C1	22 pF	VJ 1206 A 220 J XAMT
C2	22 pF	VJ 1206 A 220 J XAMT
R1	100 kΩ	CRCW-1206-1003-F-RT1
Quartz Crystal	3.686400 MHz	XT49S-20-3-3.686400M

Absolute Maximum Ratings

Parameter	Symbol	Min.	Typ.	Max.	Unit	Notes
Supply voltage	V_{CC}	-0.5		3.6	V	
Input voltage		-0.5		5.5	V	all pins
Output voltage		-0.5		$V_{CC} + 0.5$	V	all pins
Output sinking current	I_{out}	8			mA	all pins
Junction temperature	T_j			125	°C	
Ambient temperature (operating)	T_{amb}	-25		85	°C	
Storage temperature	T_{stg}	-25		85	°C	
Soldering temperature	T_{sldr}		215	230	°C	$t = 20 \text{ s @ } 215^\circ\text{C}$

DC Characteristics

Parameter	Symbol	Min.	Typ.	Max.	Unit	Notes
Operating voltage	V_{CC}	3.0	3.3	3.6	V	

$V_{CC} = 3.3 \text{ V} \pm 5\%$, operating temperature = -25°C to 85°C

Parameter	Symbol	Min.	Typ.	Max.	Unit	Notes
Input HIGH voltage	V_{IH}		1.7	2.0	V	Inputs tolerate levels as high as 5.5 V max. All inputs are Schmitt trigger inputs
Input LOW voltage	V_{IL}	0.8	1.1		V	
Input Schmitt trigger hysteresis	V_{hyst}		0.6		V	
Input leakage no pull-up/down	I_L	-10	± 1	10	μA	$V_{IN} = V_{DD}$ or GND
Output HIGH voltage	V_{OH}	2.0			V	$I_{OH} = -2.0 \text{ mA}$
	V_{OH}	2.4			V	$I_{OH} = -0.5 \text{ mA}$
Output LOW voltage	V_{OL}			0.4	V	$I_{OL} = +2.0 \text{ mA}$
Consumption Current Standby	I_{SB}			1	μA	Inputs grounded, no output load $V_{CC} = 3.3 \text{ V}$, $T = 25^\circ\text{C}$
Dynamic	I_{CC}		2		mA	



Operation Description

Figure 2 shows a typical example of an RS232 port interface. The TOIM4232 connects to an RS232 level converter on one side, and an infrared transceiver on the other. The internal TOIM4232 baud rate generator can be software controlled.

When BR/D = 0, the TOIM4232 interprets the channels TD_232 to TD_IR and RD_IR to RD_232 as data channels.

On the other hand, whenever BR/D = 1, the TOIM4232 interprets TD_232 as Control Word for setting the Baud rate. The Baud rate can be programmed to operate from 1200 bit/s to 115 kbit/s. As RS232 level converter, EIA232 or MAX232 or equivalent are recommended.

When using the TOIM4232 directly connected to an UART it is compatible to 5 V TTL and 3.3 V CMOS logic.

Typical external resistors and capacitors are needed as shown in the TFDx4xxx references.

The output pulse duration can also be programmed, see chapter "Operation Description". It is strongly recommended using 1.627 μ s output pulses to save battery power. As frequency determining component a Vishay XT49M Crystal is recommended, when no external clock is available.

We strongly recommend not to use this 3/16 mode because 3/16 pulse length at lower bit rates consumes more power than the shorter pulse. At a data rate of 9600 bit/s, the ratio of power consumption of both modes is a factor of 12 (!).

Programming the TOIM4232

For correct, data rate dependent timing the TOIM4232 is using a built-in baud rate generator. This is used when no external clock is not available as in RS232 IR-dongle applications. For programming the BR/D pin has to be set active, BR/D = 1.

In this case the TOIM4232 interprets the 7 LSBs at the TD_232 input as a Control Word. The operating baud rate will change to its supposedly new baud rate when the BR/D returns back to LOW ("0") Set the UART to 8 bit, no parity, 1 stop bit.

Control Byte (8 bit)

First Character				Second character			
X	S2	S1	S0	B3	B2	B1	B0
							LSB

where

- X: Do not care
- S1, S2: User programmable bit to program the outputs S1 and S2
- S0: IrDA pulse select
 - = (1) 1.627 μ s output pulses
 - = (0) 3/16 bit time pulses, not recommended
- B0 .. B3: Baud rate select words

Baud Rate Select Words

Note:

IrDA standard only supports 2.4, 9.6, 19.2, 57.6, and 115.2 kbit/s.

B3	B2	B1	B0	2nd Char	Baud Rate
0	0	0	0	0	115.2 k
0	0	0	1	1	57.6 k
0	0	1	0	2	38.4 k
0	0	1	1	3	19.2 k
0	1	0	0	4	14.4 k
0	1	0	1	5	12.8 k
0	1	1	0	6	9.6 k
0	1	1	1	7	7.2 k
1	0	0	0	8	4.8 k
1	0	0	1	9	3.6 k
1	0	1	0	A	2.4 k
1	0	1	1	B	1.8 k
1	1	0	0	C	1.2 k



Software for the TOIM4232

UART Programming

For proper operation, the RS232 must be programmed (using 8 bit, 1 stop, no parity) to send a two character control word, YZ. The control word YZ is composed of two characters, written in hexadecimal, in format: YZ.

The transfer rate for programming must be identical with the formerly programmed data rate, or after resetting the TOIM4232, the default rate of 9600 bit/s is used.

Software algorithm

Step	RESET	BR/D	RD_UART	TD_UART	RD_IR	TD_IR	Description and Comments
1	HIGH	X	X	X	X	X	Resets all internal registers. Resets to IrDA default data rate of 9600 bit/s.
2	LOW	X	X	X	X	X	Wait at least 7 μ s.
3	LOW	HIGH	X	X	X	X	Wait at least 7 μ s. TOIM4232 now is set to the Control Word programming mode.
4	LOW	HIGH	YZ with Y = 1 for 1.627 μ s Y = 0 3/16 bit length	X	X	X	Sending the Control Word YZ. Examples: Send '1Z' if 1.627 μ s pulses are intended to be used. Otherwise send '0Z' for 3/16 bit period pulses. 'Y6' keeps the 9.6 kbit/s data rate. Z = 0 sets to 115.2 kbit/s, see programming table. Wait at least 1 μ s for hold-time.
5	LOW	LOW	DATA	DATA	DATA	DATA	With BR/D = 0, TOIM4232 is in the data communication mode. Both RESET and BR/D must be kept LOW ('0') during data transmission. Reprogramming to a new data rate can be resumed by restarting from step 3. The UART itself also must be set to the correct data rate *).

*) For programming the UART, refer to e.g., National Semiconductor's data sheet of PC 16550 UART.

Package Information

Package SO16L

Dimensions in mm

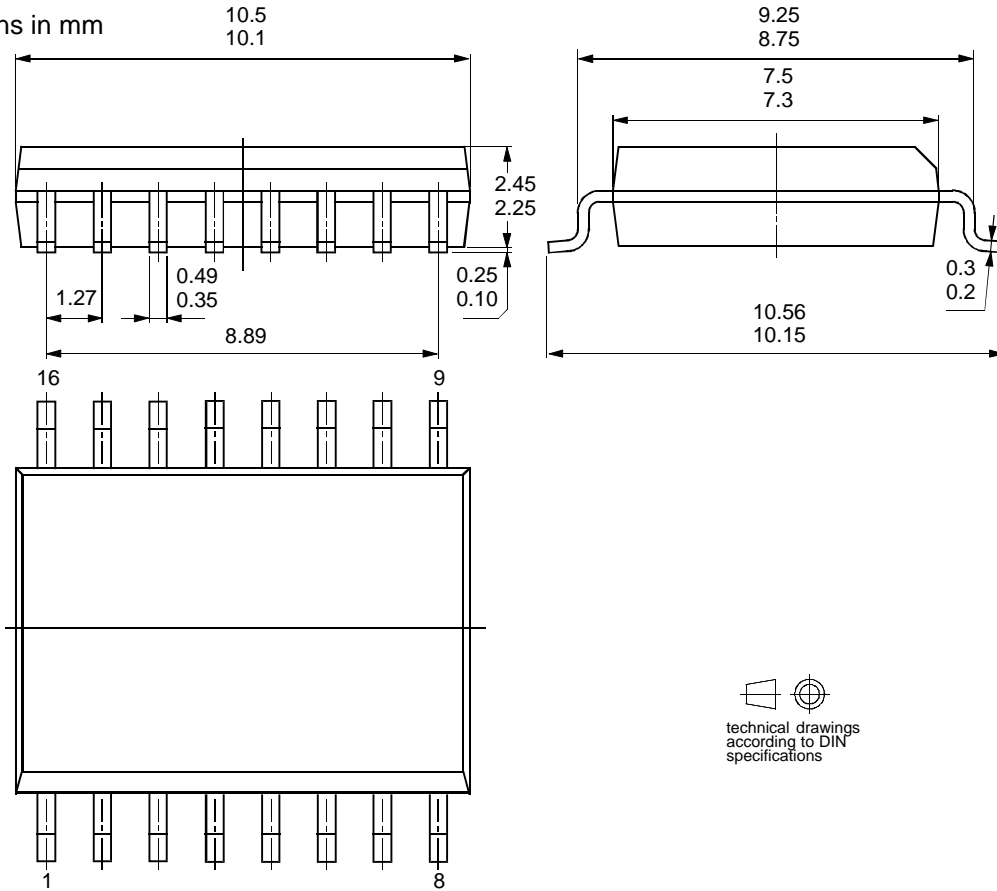

technical drawings
according to DIN
specifications

13011

Recommended Application Circuits

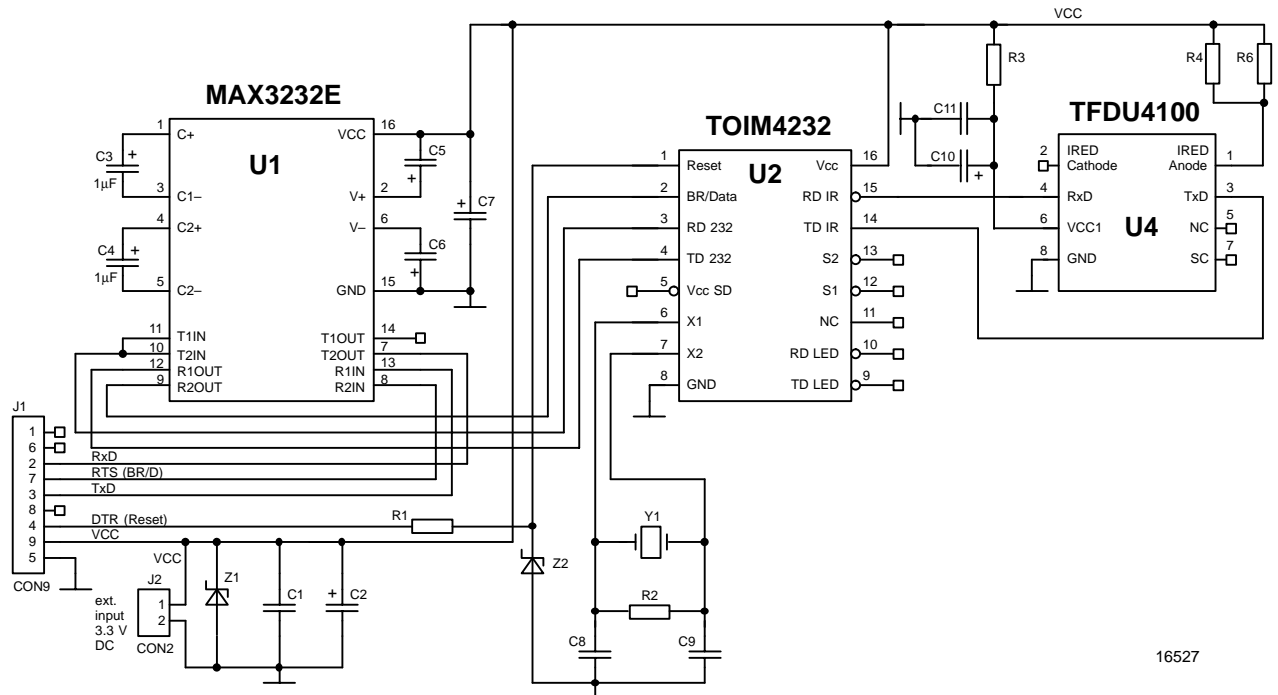

16527

Figure 3. Application circuit using TFDU4100 with an integrated level shifter MAX3232E.
When used directly with 3 V logic, this one can be emitted

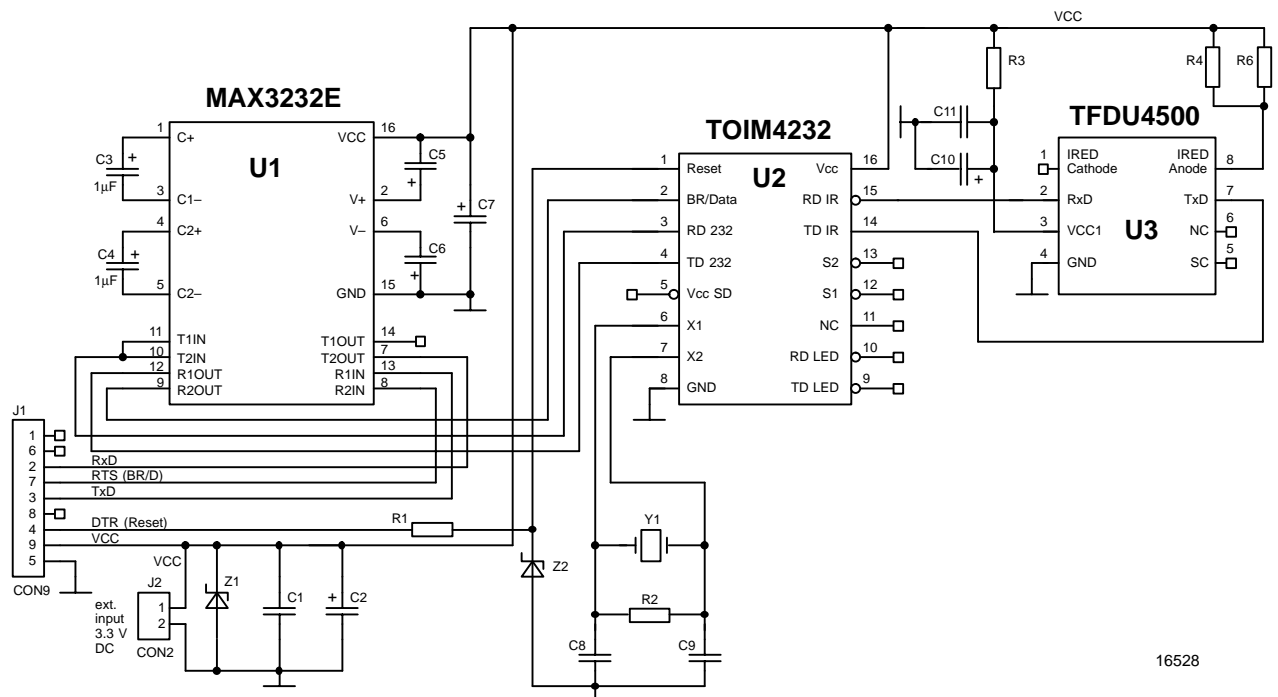

16528

Figure 4. Application circuit using TFDU4500 with an integrated level shifter MAX3232E.
When used directly with 3 V logic, this one can be emitted

Table 2. Recommended Application Circuit Components

Component	Recommended Value	Vishay Part Number
C1	100 nF	VJ 1206 Y 104 J XXMT
C2	10 μ F, 16 V	293D 106X9 016B 2T
C3	100 nF	VJ 1206 Y 104 J XXMT
C4	100 nF	VJ 1206 Y 104 J XXMT
C5	100 nF	VJ 1206 Y 104 J XXMT
C6	100 nF	VJ 1206 Y 104 J XXMT
C7	10 μ F, 16 V	293D 105X9 016A 2T
C8	22 pF	VJ 1206 A 220 J XAMT
C9	22 pF	VJ 1206 A 220 J XAMT
C10	6.8 μ F, 16 V	293D 685X9 016B 2T
C11	100 nF	VJ 1206 Y 104 J XXMT
Z1	3.6 V	BZT55C3V6
Z2	3.6 V	BZT55C3V6
R1	5.6 k Ω	CRCW-1206-5601-F-RT1
R2	100 k Ω , optional, for reducing oscillator start up time	CRCW-1206-1003-F-RT1
R3	47 k Ω	CRCW-1206-47R0-F-RT1
R4	27 k Ω	CRCW-1206-27R0-F-RT1
R6	27 k Ω	CRCW-1206-27R0-F-RT1
Y1	3.686400 MHz	XT49S-20-3.686400M
U1		MAXIM MAX 3232E
U2		TOIM4232
U3, U4		TFDS4500 or TFDS4100
J1	9 Pin – Connector	Cannon
J2	Connector	

Recommended Circuit Diagram for Using TOIM4232 and TFDS4500 in IR Adapters at the Serial Port

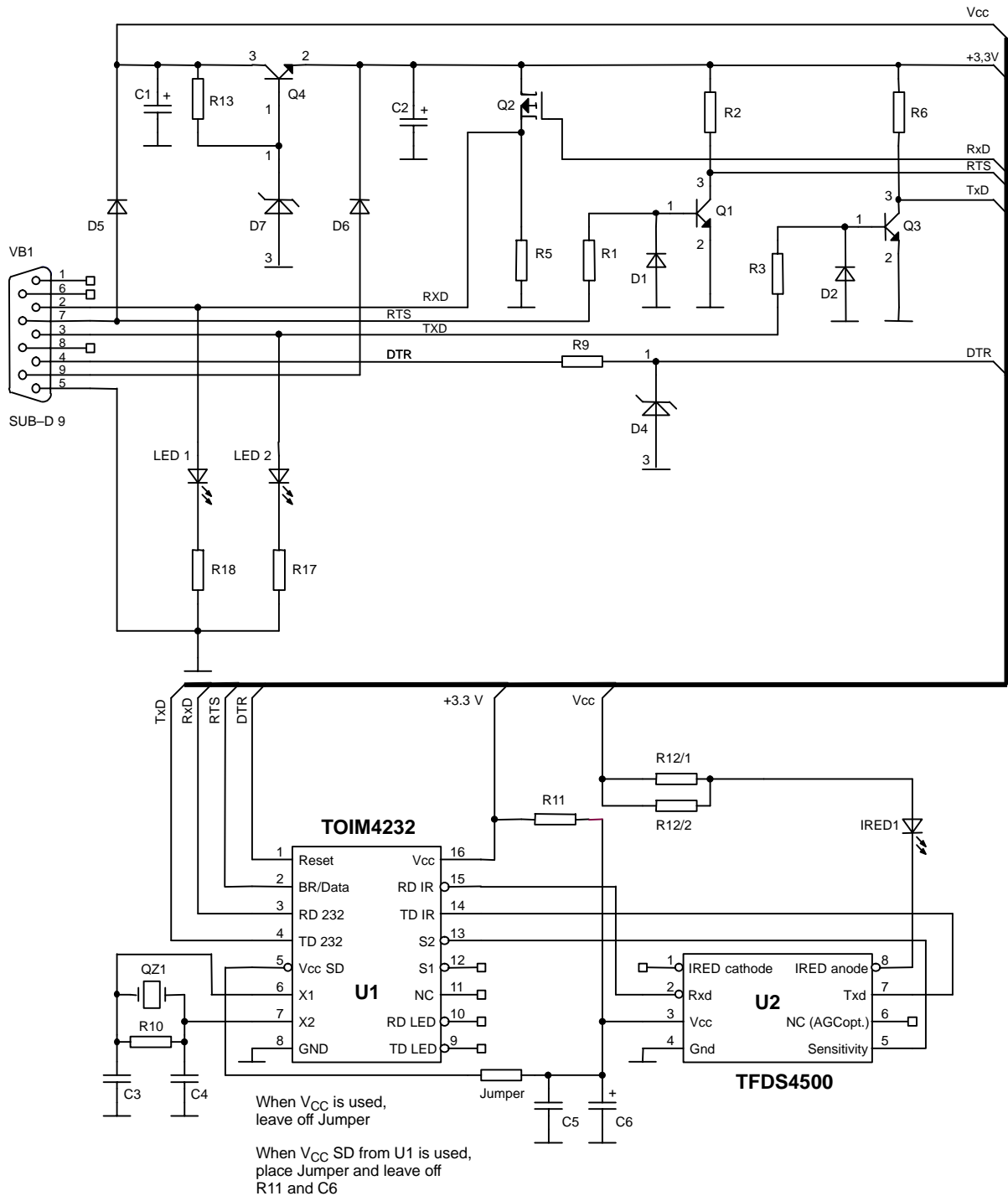

Due to the very limited power to be drawn out of the RS232 port, it is recommended to operate the LEDs for displaying the state of transmission (D3, D4) with lowest possible current or not to use this function without external power supply. PCB layout, Gerber plots, component list, and control software are available on request.

Circuit diagram refers to TOIM3232. The operating voltage for the TOIM4232 is reduced to 3.3 V typical. Therefore the equivalent component values have to be adapted.

Figure 5. Discrete solution for the interface to the RS232 port

Table 3. Recommended Application Circuit Components

Component	Recommended Value	Vishay Part Number
C1	22 μ F, 16 V	293D 226X9 016C 2T
C2	47 μ F, 16 V	293D 476X9 016D 2T
C3	22 pF	VJ 1206 A 220 J XAMT
C4	22 pF	VJ 1206 A 220 J XAMT
C5	100 nF	VJ 1206 Y 104 J XXMT
C6	6.8 μ F, 16 V	293D 685X9 016B 2T
D1		1N4148
D2		1N4148
D4		BZT55C4V7
D5		1N4148
D6		1N4145
D7		BZT55C3V9
IRED1		TSHF5400
Jumper		CRCW-1206-000-F-RT1
LED1		TLLY4401
LED2		TLLG4401
Q1		BC817-25
Q2		VP 0610 0T
Q3		BC817-25
Q4		BC817-25
QZ1	3.686400 MHz	XT49S-20-3.686400M
R1	22 k Ω	CRCW-1206-2202-F-RT1
R2	10 k Ω	CRCW-1206-1002-F-RT1
R3	22 k Ω	CRCW-1206-2202-F-RT1
R5	1 k Ω	CRCW-1206-1001-F-RT1
R6	47 k Ω	CRCW-1206-4702-F-RT1
R9	5.6 k Ω	CRCW-1206-5601-F-RT1
R10	100 k Ω , optional, for reducing oscillator start up time	CRCW-1206-1003-F-RT1
R11	100 Ω	CRCW-1206-1000-F-RT1
R12	20 Ω	CRCW-1206-20R0-F-RT1
R13	1 k Ω	CRCW-1206-1001-F-RT1
R17	750 Ω	CRCW-1206-7500-F-RT1
R18	750 Ω	CRCW-1206-7500-F-RT1
VB1	Sub-D9	Cannon
PCB		



Ozone Depleting Substances Policy Statement

It is the policy of **Vishay Semiconductor GmbH** to

1. Meet all present and future national and international statutory requirements.
2. Regularly and continuously improve the performance of our products, processes, distribution and operating systems with respect to their impact on the health and safety of our employees and the public, as well as their impact on the environment.

It is particular concern to control or eliminate releases of those substances into the atmosphere which are known as ozone depleting substances (ODSs).

The Montreal Protocol (1987) and its London Amendments (1990) intend to severely restrict the use of ODSs and forbid their use within the next ten years. Various national and international initiatives are pressing for an earlier ban on these substances.

Vishay Semiconductor GmbH has been able to use its policy of continuous improvements to eliminate the use of ODSs listed in the following documents.

1. Annex A, B and list of transitional substances of the Montreal Protocol and the London Amendments respectively
2. Class I and II ozone depleting substances in the Clean Air Act Amendments of 1990 by the Environmental Protection Agency (EPA) in the USA
3. Council Decision 88/540/EEC and 91/690/EEC Annex A, B and C (transitional substances) respectively.

Vishay Semiconductor GmbH can certify that our semiconductors are not manufactured with ozone depleting substances and do not contain such substances.

We reserve the right to make changes to improve technical design and may do so without further notice.

Parameters can vary in different applications. All operating parameters must be validated for each customer application by the customer. Should the buyer use Vishay Telefunken products for any unintended or unauthorized application, the buyer shall indemnify Vishay Telefunken against all claims, costs, damages, and expenses, arising out of, directly or indirectly, any claim of personal damage, injury or death associated with such unintended or unauthorized use.

Vishay Semiconductor GmbH, P.O.B. 3535, D-74025 Heilbronn, Germany
Telephone: 49 (0)7131 67 2831, Fax number: 49 (0)7131 67 2423